



SPECIFICATIONS & MOUNTING INSTRUCTIONS

AC Triton

Input voltage range is 115 to 277vAC, 50-60 Hz
Input current is 1.4A @ 115vAC, 0.6A @ 277vAC

12 Volt DC Triton

Voltage is 12vDC ONLY
Current is 13.2A @12vDC

24 Volt DC Triton

Voltage is 24vDC ONLY
Current is 6.6A @ 24vDC

All Versions

Correlated Color Temperature: 6500K
Color Rendering Index: 65+
Lumens: 12930

AC Triton Wiring

White: Neutral
Black: Line
Green: Safety Ground

The ground (green) conductor is not internally connected to either the neutral (white) or line (black) conductors. The ground conductor must be connected to a suitable safety ground in compliance with applicable electrical codes. The electrical supply must be externally protected by a fuse or circuit breaker suitable for the intended operating current.

DC Triton Wiring

White: + 12 or + 24vDC (Positive)
Black: - 12 or - 24vDC (Negative)

The positive (white) and negative (black) conductors are electrically isolated from the Triton housing. Due to the high power of these lights, extra attention should be paid to the selection of the wire size. A maximum voltage drop of 1 volt is recommended. As an example, a 12 volt light located 20 feet from the power source would require #12 AWG wire – consult the ABYC voltage drop table or other reference for the correct distance / wire gauge combinations. The electrical supply must be externally protected by a fuse or circuit breaker suitable for the intended operating current and wire gauge.

Light Head Assembly Installation

The Triton Light Head Assembly is designed for OEM use. This light requires an area of 14" x 5 1/2" for mounting. Make sure adequate space is available on the mounting surface before drilling holes (see back). Drill a 1/2" through hole in the center of the mounting position for the power wires to pass. This light arrives with 4 temporary plastic wings nuts on each of the 4 corner bolts. Remove the wing nuts and use the 4 remaining 10-24 machine screws with your choice of nuts. Or, replace the 4 corner bolts with your choice of #10 tapping screw. Stainless steel hardware is recommended.

Pole Mount/Bracket Mount Installation

Pole Mount - This light comes equipped with a 3/4" NPT flange for easy mounting in many standard configurations.
Bracket Mount - This light comes equipped with a rotational mounting bracket intended for mounting to flat surfaces. Mounting hardware can be substituted but it is recommended that stainless steel hardware be used regardless of fastener type.

Surface Mount Installation

This light requires an area of 14" x 5 1/2" for mounting. Make sure adequate space is available on the mounting surface before drilling holes (see back). Drill a 1/2" through hole in the center of the mounting position for the power wires to pass. This light arrives with 4 temporary plastic wings nuts on each of the 4 corner bolts. Remove the wing nuts and use the 4 remaining 10-24 machine screws with your choice of nuts. Or, replace the 4 corner bolts with your choice of #10 tapping screw. Stainless steel hardware is recommended. Apply a small ring of silicone RTV around the wire exit hole on the rear of the surface mount plate to ensure proper sealing. Make sure when the light is mounted that the Triton badge reads normally, not upside down. This will ensure proper airflow for cooling.

Semi-Recess Mount Installation

This light requires an area of 17 1/2" x 9 1/2" for mounting and requires a hole 15 1/4" wide by 7 1/4" tall by 1 1/2" deep to be cut into the mounting surface (see back). Make sure adequate space is available on the mounting surface before drilling holes. After the recess hole is cut, place and use the light assembly to mark the centers of each mounting screw position. Pre-drill holes appropriately sized for the mounting surface substrate to accommodate the #10 self-tapping screws. Apply a bead of silicone RTV around the entire rear flange of the recess mount and around mounting screw holes to ensure proper sealing. Connect the power wires, position, and use the 8 - #10 screws provided to securely mount the fixture in place. Make sure when the light is mounted that the Triton badge reads normally, not upside down. This will ensure proper airflow for cooling.

IMPORTANT

Maximum light output is obtained when light has proper cooling via air flow. If poorly ventilated, the light is programmed to reduce power to compensate.

Limited Warranty

The product is warranted to be free from defects in workmanship and materials for a period of one year from the date of original purchase. Lumitec is not responsible for product failure caused by abuse, neglect, improper installation, or failure in applications other than those for which it was designed, intended, and marketed. Should your Lumitec product prove defective during the warranty period, promptly notify Lumitec and return product with freight prepaid. Lumitec will, at its option, repair or replace the product or defective portion without charge for parts or labor, or, at Lumitec's option, refund purchase price. Products repaired or replaced under this warranty shall be warranted for the unexpired portion of the warranty applying to the original product(s). No warranty or affirmation of fact, express or implied, other than as set forth in the limited warranty statement above is made or authorized by Lumitec, LLC. Any liability for consequential and incidental damages is expressly disclaimed. Lumitec's liability in all events is limited to, and shall not exceed, the purchase price paid.

Lumitec, LLC - 1405 Poinsettia Drive, Suite 10 - Delray Beach, FL 33444 - lumiteclighting.com - 561-272-9840

Light Head Assembly

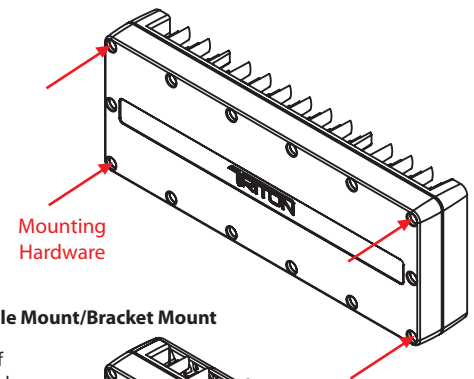

Pole Mount/Bracket Mount

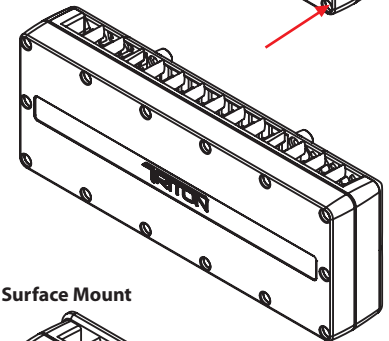

Surface Mount

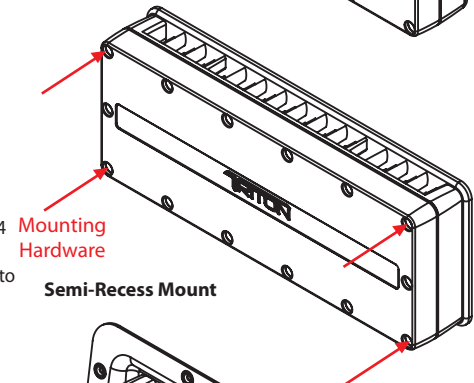

Semi-Recess Mount

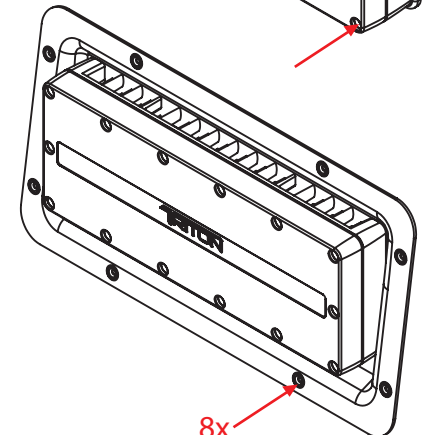

8X
Mounting
Hardware



LUMITEC

Light Head Assembly & Surface Mount Mounting Hole Locations

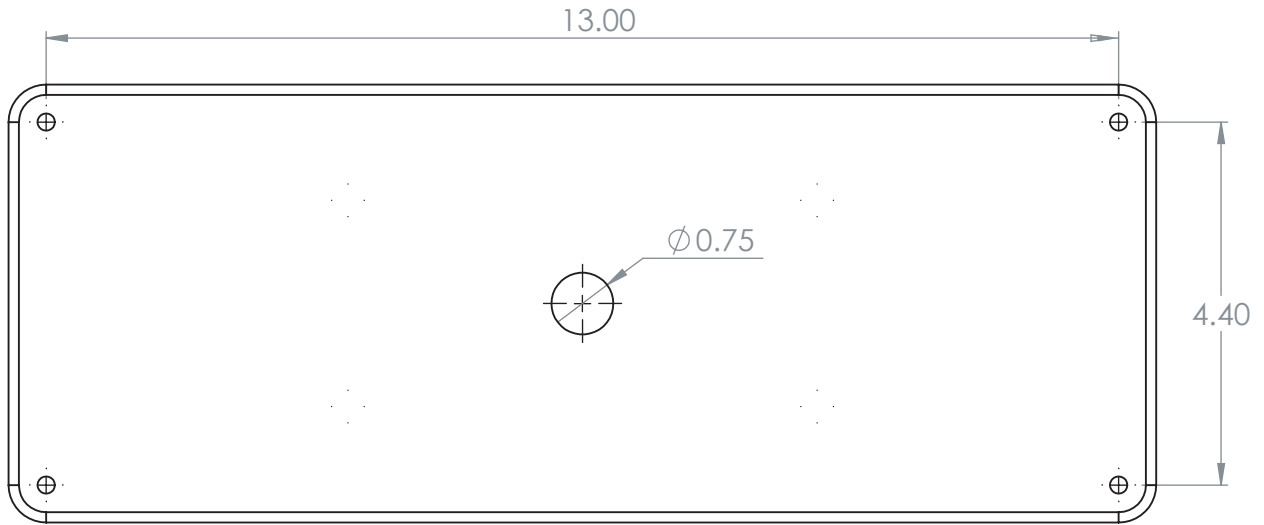

Semi-Recess Mount Mounting Hole Locations

